

THE MICROMETER

Name _____

Date _____

Objectives: Students will familiarize themselves with the micrometer and accurately read measurements.

Directions: In order to successfully complete the Machinist or Lathe activity, you must be able to accurately measure with a micrometer. The following will take about two class periods.

What is a Micrometer:

A micrometer is a measuring device that can measure very small amounts. A machinist would use a micrometer to meet a **tolerance** (a range of variation in size that the produced work can be off from the standard usually in thousands of an inch.....Example: ± 0.005 " [Read as plus or minus five thousandths]) for a particular product. You will be using an external micrometer that has markings for the inch system of measurement. It can measure up to one thousandth of an inch.

Parts of a Micrometer:

Shown in Figure 1 below is a picture of a micrometer with the four main parts or areas identified. A micrometer will be needed for the next part; get your micrometer at this time.

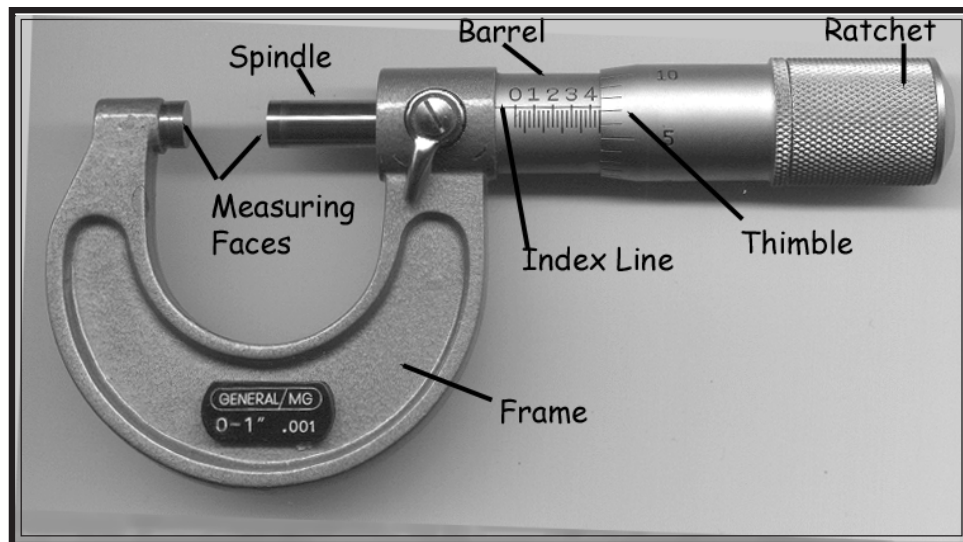

Figure 1.

Look at the picture and the micrometer that you have. The student must be able to quickly identify measurements and the parts of the micrometer that are needed to take the measurements. Hold the frame of the micrometer in your left hand. Turn the ratchet on the thimble with your right hand. This will move the thimble up and down the barrel, which will move the spindle in or out.

Always use the ratchet (sometimes there is a friction screw instead of a ratchet) to close the spindles on an object. Otherwise incorrect measurements will result! There is also a *Locking Lever* which fixes the position of the thimble and right-hand measuring rod. The micrometer is a precision instrument and should be treated with care, it should **NEVER be forced**.

Look at Figure 1 and then at the micrometer that you have. Identify the marks on the *barrel* of the micrometer. Each mark on the barrel is equal to 0.025” (twenty-five thousandths). Each line on the barrel with a number above it represents 0.100” (one hundred thousandths). The number “2” is 0.200 (two hundred thousandths), and the number “3” is 0.300 (three hundred thousandths).

Next look at figure 2 and the micrometer that you have and identify the marks on the thimble (sometimes called a sleeve). Each of the marks on the thimble is equal to 0.001 (one thousandth). The marks on the thimble go around the barrel. The mark that is read will line up with the index line. In figure 2, the ten lines up with the index line. It is written and read as 0.010 (ten thousandths).

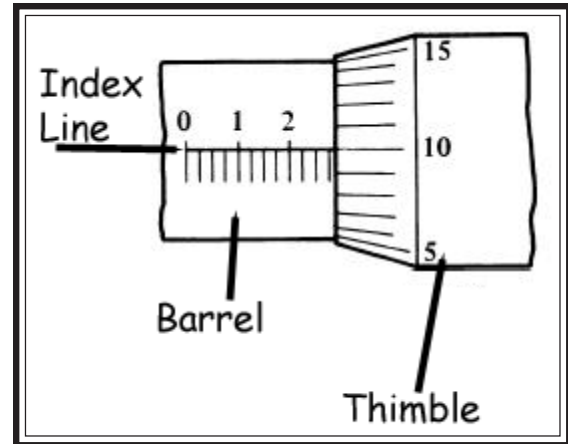

Figure 2

Turn the thimble and find the number 20. Using that as a reference point, continue turning the thimble until you come to the number 20 again. Notice that either more or less (depending on the direction that you turned the thimble) of the barrel has been exposed. The combination of numbers are used to determine the measurement. Consequently, we need to review your addition and subtraction skills.

Math Review:

Students must be able to accurately add and subtract decimal numbers. So we will have a real quick review. When adding or subtracting decimals, write the problem in a stacked up fashion and keep the decimals in line. For example, the problem $0.500 + 0.034 + 0.003 =$ would be written as

$$\begin{array}{r}
 0.500 \\
 +0.034 \\
 0.003 \\
 \hline
 0.537
 \end{array}$$

Work the following problems. You must get 16 of 20 problems correct to continue. Check your own work with a calculator that the teacher will provide. Write down the correct answers by the ones you missed.

- | | | | | | | |
|--------------------------------------|---------------------------------------|--------------------------------------|--------------------------------------|-----------------------------|--------------------------------------|-----------------------------|
| a. 0.500
+0.025
0.001
_____ | b. 0.400
+ 0.050
0.019
_____ | c. 0.600
+0.025
0.007
_____ | d. 0.125
+0.025
0.005
_____ | e. 0.275
-0.012
_____ | f. 0.900
+0.025
0.012
_____ | g. 0.943
-0.125
_____ |
| h. 0.100
+0.075
0.008
_____ | i. 0.813
+ 0.029
0.021
_____ | j. 0.500
+0.075
0.003
_____ | k. 0.200
+0.075
0.022
_____ | l. 0.300
-0.050
_____ | m. 0.600
+0.050
0.004
_____ | n. 0.943
-0.023
_____ |

o. 0.700	p. 0.400	q. 0.700	r. 0.600	s. 0.400	t. 0.300
+0.025	+0.050	+0.075	+0.050	-0.011	+0.075
<u>0.017</u>	<u>0.008</u>	<u>0.012</u>	<u>0.009</u>	<u> </u>	<u>0.016</u>

The next step is to practice reading measurements from the micrometer. Remember that each mark on the barrel equals 0.025", each numbered line on the barrel equals 0.100", and each line on the thimble equals 0.001".

Look at figure 3 and ask yourself the following questions:

1. What is the highest numbered line on the barrel that you can see?
2. How many lines on the barrel do you see past the number two?
3. What mark on the thimble lines up with the index line on the barrel?

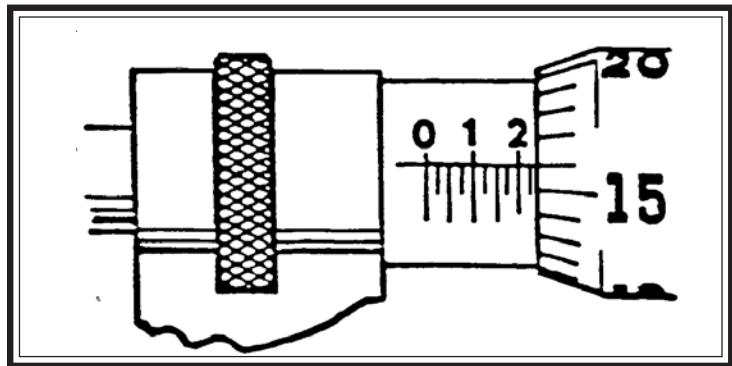

Figure 3

The answer to question number 1 should have been The line with the number two (2) is the highest number to show on the barrel. The answer to question number 2 should have been there is 1 line past the 2 on the barrel. The last answer should have been a 16 is showing on the thimble.

Putting this all together:

$$\begin{array}{r}
 2 \text{ (highest number on the barrel)} \times 0.100 \text{ equals } \mathbf{0.200''} \\
 1 \text{ (number of marks past the 2)} \times 0.025 \text{ equals } \mathbf{0.025''} \\
 16 \text{ (marks on the thimble)} \times 0.001 \text{ equals } \mathbf{0.016''} \\
 \text{Total Reading equals } \mathbf{0.241''}
 \end{array}$$

This is read as "two hundred forty-one thousandths."

Look at figure 4, and calculate the reading. Ask these questions:

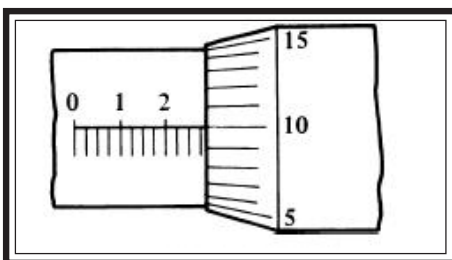

Figure 4

1. What is the highest numbered line on the barrel that you can see?
2. How many lines on the barrel do you see past the number two?
3. What mark on the thimble lines up with the index line on the barrel?

The answers are:

$$\begin{array}{r}
 2 \text{ (highest number on the barrel)} \times 0.100 \text{ equals } \mathbf{0.200''} \\
 3 \text{ (number of marks past the 2)} \times 0.025 \text{ equals } \mathbf{0.075''} \\
 10 \text{ (marks on the thimble)} \times 0.001 \text{ equals } \mathbf{0.010''} \\
 \text{Total Reading equals } \mathbf{0.285''}
 \end{array}$$

This is read as "two hundred eighty-five thousandths."

THE MICROMETER QUIZ

Directions: Answer each of the following questions. This is an open booklet quiz, you may look back in the booklet as often as you like. It is not an “open neighbor” or “open friend” quiz. Do your own work.

1. Add the following numbers: $0.400 + 0.090 + 0.003 = ??$
2. Add the following numbers: $0.300 + 0.080 + 0.023 = ??$
3. Add the following numbers $0.924 - 0.065 = ??$
4. Identify and label the parts indicated on the drawing of the micrometer.

- a. _____
- b. _____
- c. _____
- d. _____

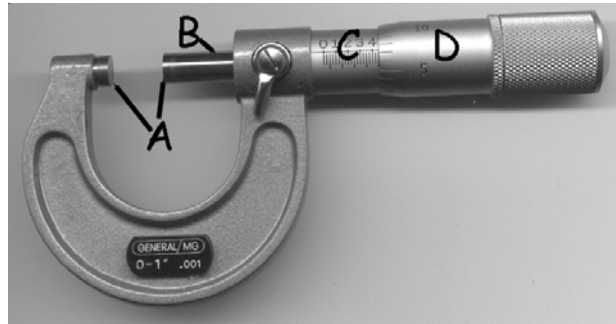

5. Each mark on the barrel of the micrometer represents _____ of an inch? Give the decimal.
6. Each mark on the thimble of the micrometer is equal to _____ of an inch? Give the decimal.
7. Each numbered mark on the barrel is equal to _____ of an inch? Give the decimal.
8. Give the decimal number that the number “7” on the barrel represents. _____
9. Give the decimal number that the number “5” on the thimble represents. _____
10. A tolerance is an allowed _____ in size.

11- 20. **Directions:** Supply the information asked for, for each of the sample micrometer readings pictured on the following page. The first one has been done for you. On the last problem you will need a micrometer. Take the micrometer to your instructor who will direct you on what to measure for problem 20.

- a. What is the last numbered line that is visible?
- b. The decimal equivalent of this number is?
- c. How many lines are visible past the last numbered line?
- d. This equals how many thousandths?
- e. What is the reading from the thimble or sleeve?
- f. This equals how many thousandths?
- g. Give the final micrometer reading.

	Lasr Visible Numbered Line	Decimal Equivalent	Number of Lines Visible	Equals ??? Thousandths	Thimble Reading	Equals ??? Thousandths	ADD	Final Reading
11.	2	0.200	3	0.075	10	0.010	0.200 0.075 0.010	0.285
12.								
13.								
14.								
15.								
16.								
17.								
18.								
19.								
20.								

